

REV.	ECN NO	LOCATIONS	DESCRIPTION	DATE	REVISER	APPD

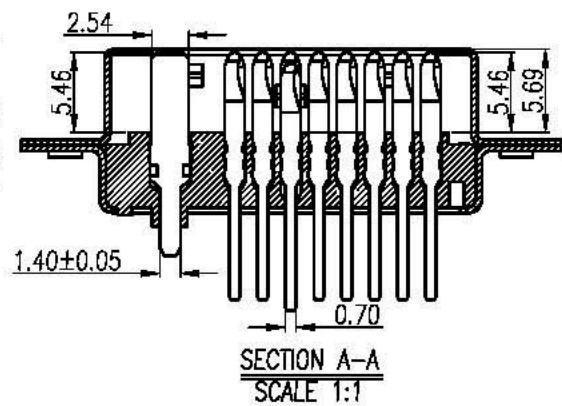
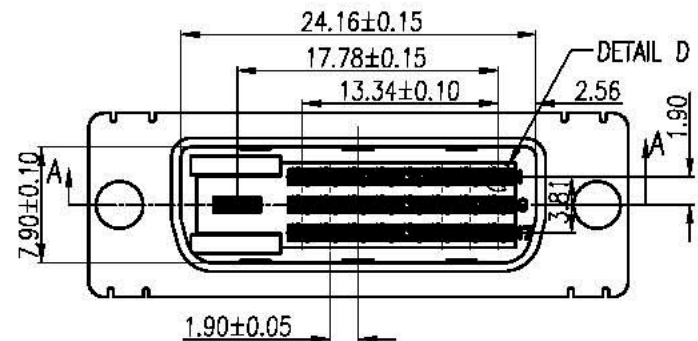

Note:

1. Material:
- 1.1 Insulator: P.B.T UL 94-V0 rated.
 - 1.2 Contact: Brass, t=0.45mm.
 - 1.3 Contact: Brass, t=0.40mm.
 - 1.4 Shell: Cold rolled steel, t=0.40mm.

2. Specification:

- 2.1 Current rating: 1 A Max.
- 2.2 Dielectric withstanding voltage: 500 V(ac) for 1 minute.
- 2.3 Contact resistance: 30 mΩ Max.
- 2.4 Insulation resistance: 1000 MΩ Min at DC 500V.
- 2.5 Mating force: 3.0kg Max.
- 2.6 Unmating force: 1.0kg Min.
- 2.7 Temperature range: -55°C~+105°C

3. Finishes:

- 3.1 contacts: Gold flashed 1u", 3u", 5u", 10u", 15u", 30u".
- 3.2 Shell: Nickel, Tin Or Gold plated.

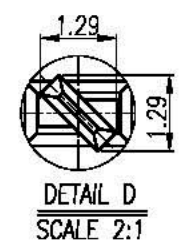
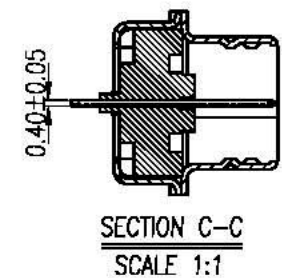
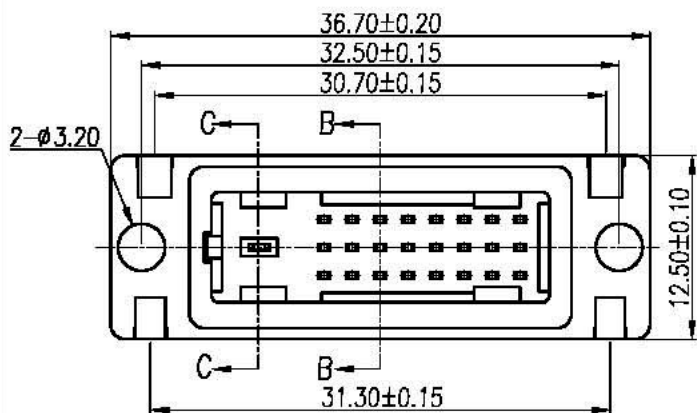
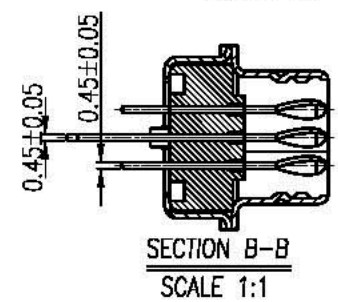
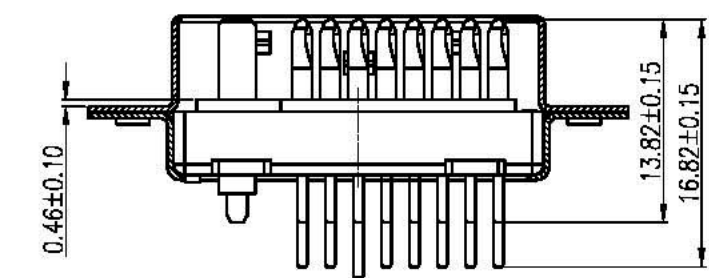

5	Back-shell	1	Cold rolled steel	T=0.40mm	Tin Plated
4	Front-shell	1	Cold rolled steel	T=0.40mm	Nickel Plated
3	Contact	1	Brass	T=0.40mm	Gold Flashed
2	Contact	24	Brass	T=0.45mm	Gold Flashed
1	Housing	1	P.B.T	UL 94-V0	Black/Ivory
No.	Name	Q'ty	Material	Remarks & Thickness	Finish

PART NO:		MATERIAL:		CHANG ENN CO., LTD.	
MODEL NO:		FINSH:			
UNIT: mm	SIZE: A4	COLOR:		PART NAME:	
TOLERANCE UNSPECIFIED		DR: '06/05/11		DVI 24+1(M)SOLDER	
.x ±0.3	.xx ±0.20	CHK: '06/05/11		DWG NO: PND33-01	
.xxx ±0.100	ANG. ±1°	APP: '08/05/11		REV: A1	
				SCALE: 1:1	SHEET: 1 of 1