

REV.	ECN NO	LOCATIONS	DESCRIPTION	DATE	REVISER	APPD

Note:

1.Material:

- 1.1 Insulator: P.B.T 30% G/F UL 94-V0 rated.
- 1.2 Contact: Brass t=0.25mm.
- 1.3 SPRING: SUS, t=0.20mm.

2.Specification:

- 2.1 Current rating: 1 A Max.
- 2.2 Dielectric withstanding voltage: 500 V(ac) for 1 minute.
- 2.3 Contact resistance: 30 mW Max.
- 2.4 Insulation resistance: 1000 MW Min at DC 500V.
- 2.5 Total mating force: 1.5 Kgf Max.
- 2.6 Total unmating force: 0.2 Kgf Min.
- 2.7 Temperature range: -55°C~+105°C

3.Finishes:

- 3.1 Contacts: Gold flashed 1u", 3u", 5u", 10u", 15u", 30u".

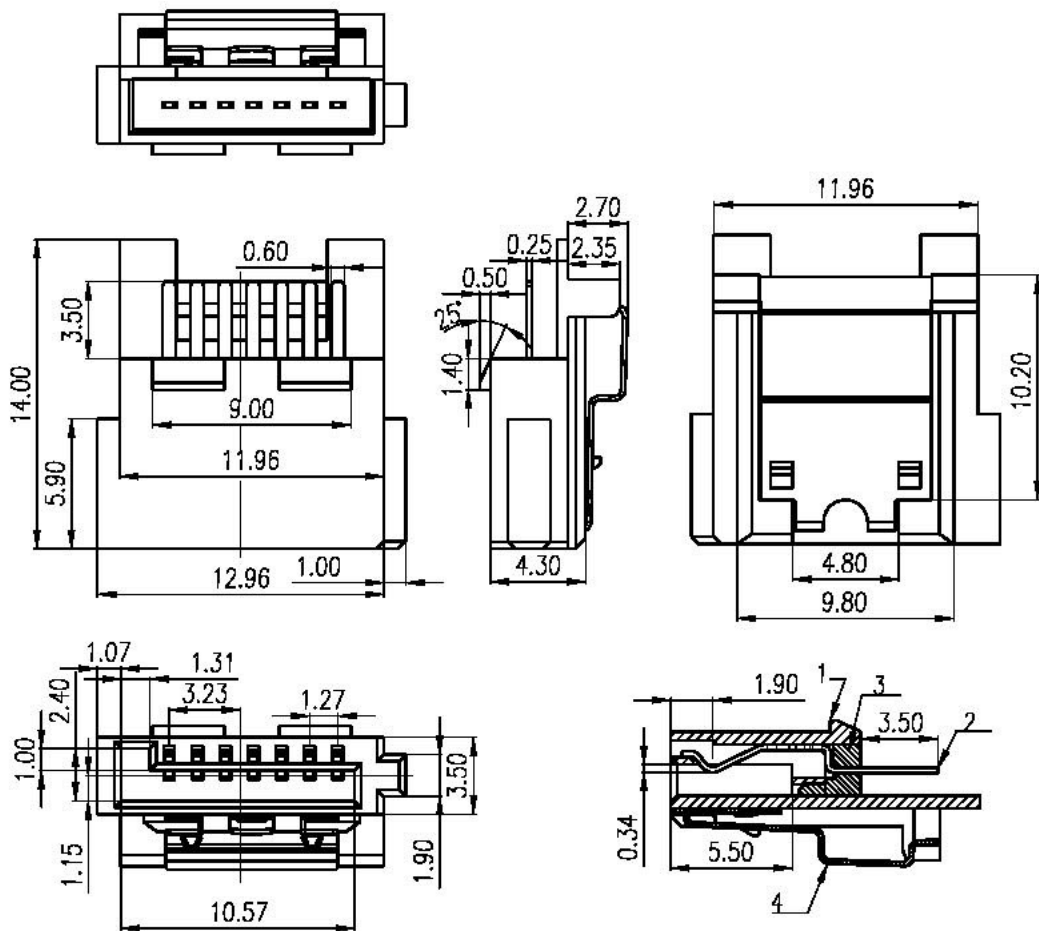

3	Spring	1	Stainless	T=0.20mm	N/A
3	Hood	1	P.B.T	UL 94-V0	Black
2	Contact	7	Brass	T=0.25mm	Gold Flashed
1	Housing	1	P.B.T	UL 94-V0	Black
No.	Name	Q'ty	Material	Remarks & Thickness	Finish

PART NO:		MATERIAL:		CHANG ENN CO., LTD.	
MODEL NO:		FINSH:			
UNIT: mm	SIZE: A4	COLOR:		PART NAME:	
TOLERANCE UNSPECIFIED		DR: '06/03/07		SATA-7PIN(F) SOLDER 加平面彈片	
.x	±0.20	CHK: '06/03/07		DWG NO: PND31-04	
.xx	±0.10	APP: '06/03/07		REV: A0	
.xxx	±0.05	SCALE: 1:1		SHEET: 1 of 1	
ANG.	±1°	SHEET: 1 of 1			