

REV.	ECN NO	LOCATIONS	DESCRIPTION	DATE	REVISER	APPD

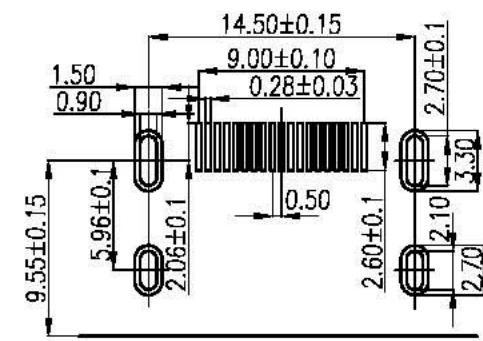

RECOMMENDED PCB LAYOUT
 GENERAL TOLERANCE ±0.05
 T=1.6±0.15

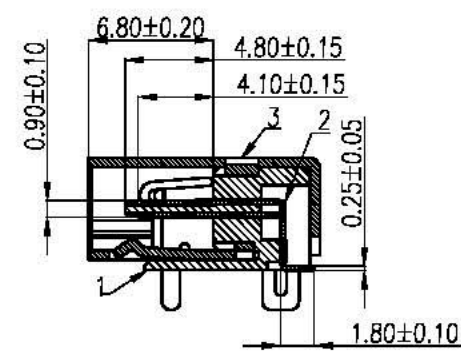
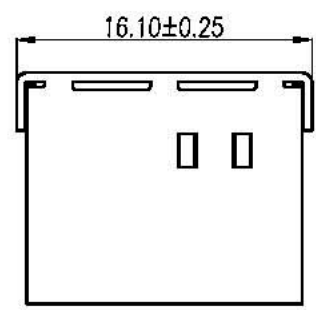
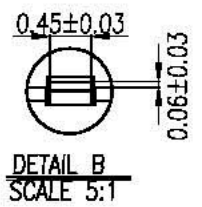
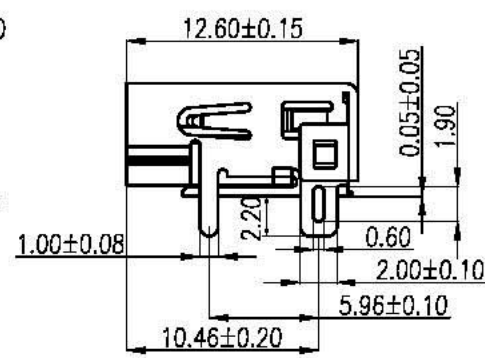
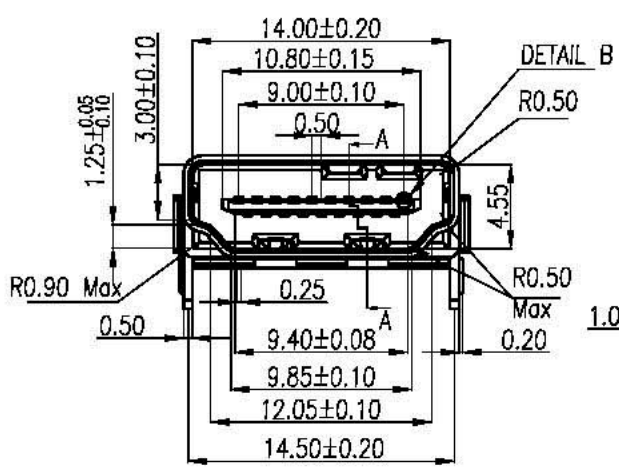

Note:

1.Material:

- 1.1 Insulator: LCP UL94V-0 color:black.
- 1.2 Contact: Phosphor bronze T=0.25mm.
- 1.3 Shell: Brass,t=0.50mm.

2.Specification:

- 2.1 Current rating: 0.5 A Max.
- 2.2 Voltage rating:40V AC(rms) Max.
- 2.3 Contact resistance: 30 milliohms Max.
- 2.4 Dielectric withstanding voltage:100V(ac) for 1 min.
- 2.5 Insulation resistance: 1000 MΩ Min.
- 2.6 Operation temperature range:-25°C~+85°C

PART NO:		MATERIAL:		CHANG ENN CO., LTD.			
MODEL NO:		FINSH:					
UNIT: mm	SIZE: A4	COLOR:		PART NAME: HDMI-19S SMT 鐵殼帶凸點			
TOLERANCE UNSPECIFIED		DR:		DWG NO: PND32-04		REV: AO	
.x	±0.3	06/03/28		SCALE: 2.5:1		SHEET: 1 of 2	
.xx	±0.20	CHK: 06/03/28					
.xxx	±0.100	APP: 06/03/28					
ANG.	±1'						