

REV.	ECN NO	LOCATIONS	DESCRIPTION	DATE	REVISER	APPD

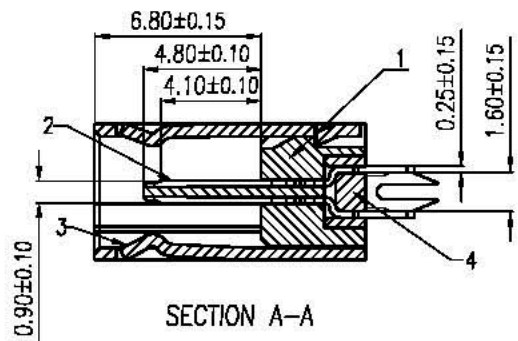

Note:

- Material:
 - Insulator: Thermoplastic UL94V-0 color:black.
 - Contact: Phosphor bronze T=0.25mm.
 - Shell: Brass,t=0.50mm.
- Specification:
 - Current rating: 0.5 A Max.
 - Voltage rating:40V AC(rms) Max.
 - Contact resistance: 50 milliohms Max.
 - Dielectric withstanding voltage:100V(ac) for 1 min.
 - Insulation resistance: 1000 MΩ Min.
 - Operation temperature range:-25°C~+85°C

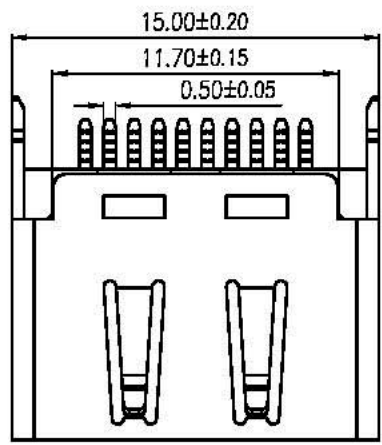
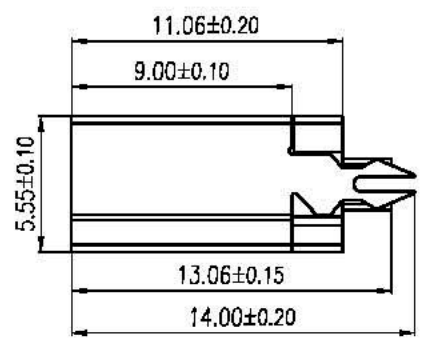
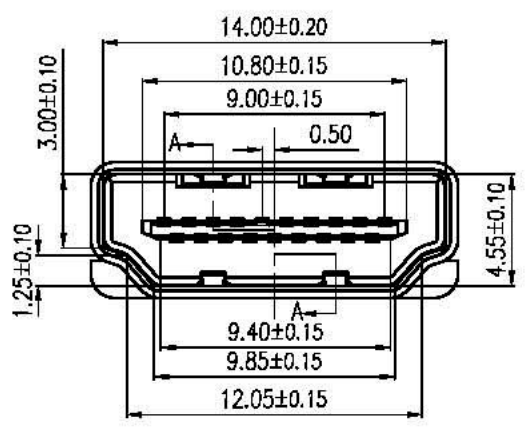

PART NO:		MATERIAL:		CHANG ENN CO., LTD.				
MODEL NO:		FINISH:						
UNIT: mm	SIZE: A4	COLOR:		PART NAME: HDMI-19PIN(F) 180°DIP				
TOLERANCE UNSPECIFIED		DR:		'06/09/06		DWG NO: PND32-05		REV: A0
.x	±0.3	CHK:		'06/09/06		SCALE: 3:1		SHEET: 1 of 2
.xx	±0.20	APP:		'06/09/06				
.xxx	±0.100							
ANG.	±1°							