

REV.	ECN NO	LOCATIONS	DESCRIPTION	DATE	REVISER	APPD

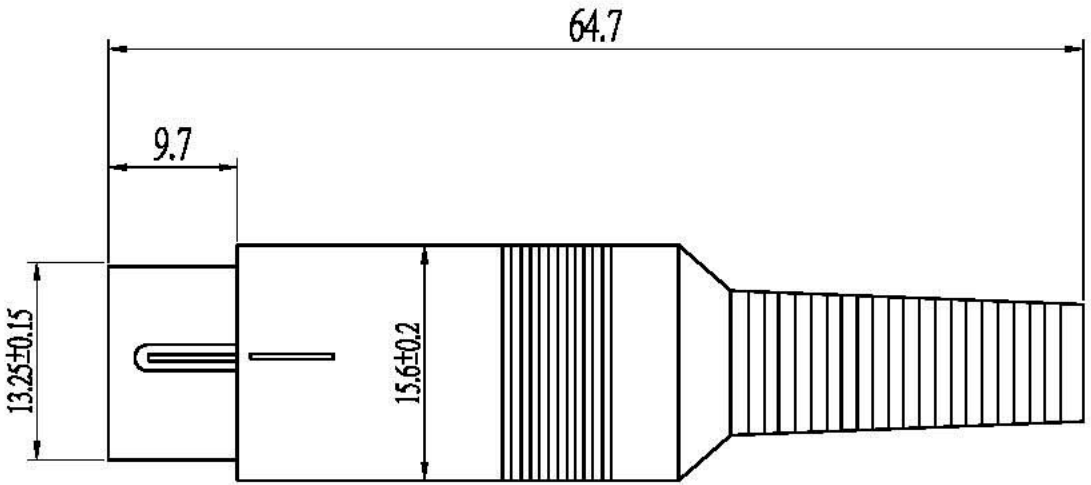

Note:
1. Material:
 1.1 Insulator: High temperature thermoplastic with g.f,UL94v-0
 1.2 Contact: Copper alloy,t=0.20mm
 1.3 Shell: Spcc,t=0.30mm
2. Specification:
 2.1 Current rating: 1 A Max.
 2.2 Dielectric withstanding voltage: 750 V(ac) for 1 min.
 2.3 Contact resistance: 30 mΩ Max.
 2.4 Insulation resistance: 1000 MΩ Min.
 2.5 Total mating force: 5.5 Kgf Max.
 2.6 Total unmating force: 1.0 Kgf Min.
 2.7 Temperature range: -55°C~85°C

8	Back-shell			
7	Front-shell			
6	Clip			No finish
5	Contact			Selective Au plated on mating area
4	Contact			
3	Contact			
2	Contact			
1	Housing			Black
No.	Name	Qty	Part No.	Finish

NO.OF CONTACT	3(180°)	4(210°)	5(180°)	6(240°)	7(270°)	8(270°)
PART NO.	DIN-3P	DIN-4P	DIN-5P	DIN-6P	DIN-7P	DIN-8P
POSITION						

PART NO:		MATERIAL:		CHANG ENN CO., LTD.	
MODEL NO:		FINISH:			
UNIT: mm	SIZE:	COLOR:		PART NAME:	
TOLERANCE UNSPECIFIED		DR:		DIN (M) ASSEMBLY	
.x	±0.3	CNC:		DMG NO: PND34-02	REV: A0
.xx	±0.20	APP:		SCALE: 2:1	SHEET: 1 of 1
.xxx	±0.100				
ANG.	±1°				