

Short Screw

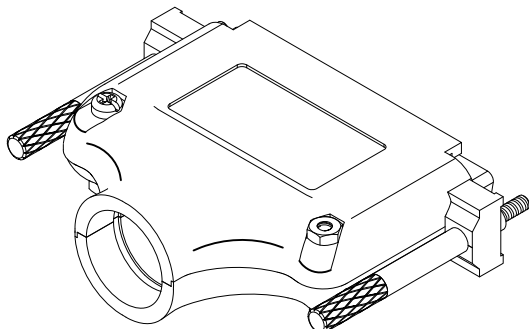

Long Screw

Material :Zinc Alloy
Finished :Nickel Plated

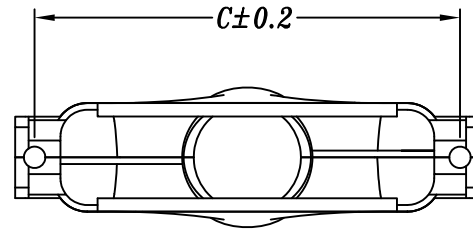

$D \pm 0.5$

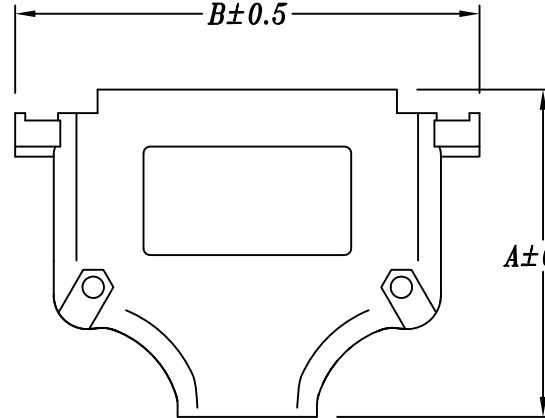

20.8

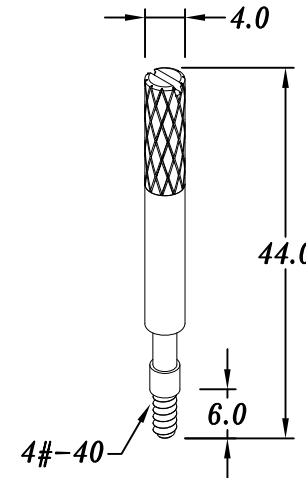
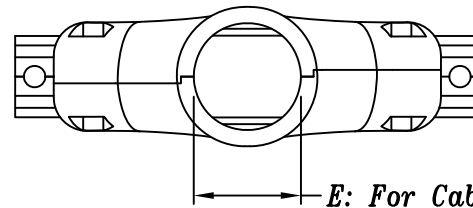

(STL-4*44-1)

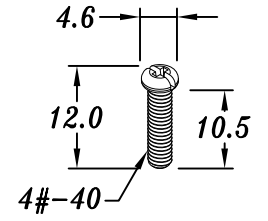

(STF-4*12.5)

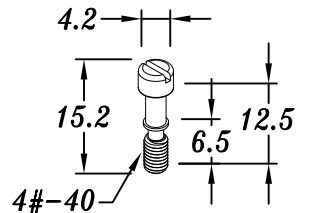

(STB-4*12.5)

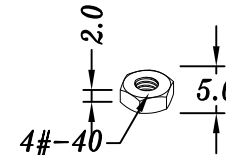

(SN-4*5)

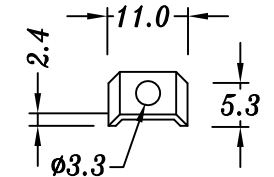

(SSW-4)

	$A \pm 0.5$	$B \pm 0.5$	$C \pm 0.2$	$D \pm 0.5$	$E \pm 0.2$ (For Cable DIA)
09	48.3	31.2	24.99	15.7	4.0/6.0/6.5/7.0/7.5/8.0/8.5/9.5
15	48.6	69.3	63.5	16.2	7.0/8.0/9.0/10.5

	$A \pm 0.5$	$B \pm 0.5$	$C \pm 0.2$	$D \pm 0.5$	$E \pm 0.2$ (For Cable DIA)
25	48.8	53.9	47.04	16.0	7.0/8.0/9.0/10.0/11.0/12.0
37	48.6	69.3	63.5	16.2	9.0/11.5/13.5/16.0

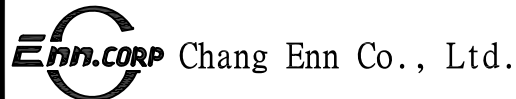

NO.410, FU-TEH 1ST ROAD,
SHIJR, TAIPEI COUNTY
221, TAIWAN, R.O.C.

TEL: 886-2-26945824

FAX: 886-2-26946971

TITLE

D-SUB Metal Hood
(V-Type)

PARTS NO.

PM01-09~37

DWG, NO.

GENERAL
TOLERANCE

DIM:
X. ± 0.30
X.X ± 0.20
X.XX ± 0.10

DRAWN

CHECK

APPROVE

SCALE

DATE 94/10/30

DATE 103/12/14

DATE

UNIT MM REV. A