

MATERIAL:

- 1.1 Insulator: P.B.T /UL 94V-0 Rated. Color Blue /White /Black.
- 1.2 Contact: Copper Alloy /t=0.20mm.
- 1.3 Shell: Cold Rolled /t=0.35mm.

SPECIFICATIONS:

- 2.1 Current Rating: 1 A Max.
- 2.2 Dielectric Withstanding Voltage: 500 V(AC) For 1 Min.
- 2.3 Contact Resistance: 30mΩ Max.
- 2.4 Insulation Resistance: DC 500V to 1000MΩ Min.
- 2.5 Temperature Range: -55°C ~ + 105°C.

FINISHES:

- 3.1 Contact: Gold Flashed 1u",3u",5u",10u",15u",30u".
- 3.2 Shell: Nickel Plated.

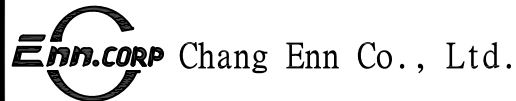
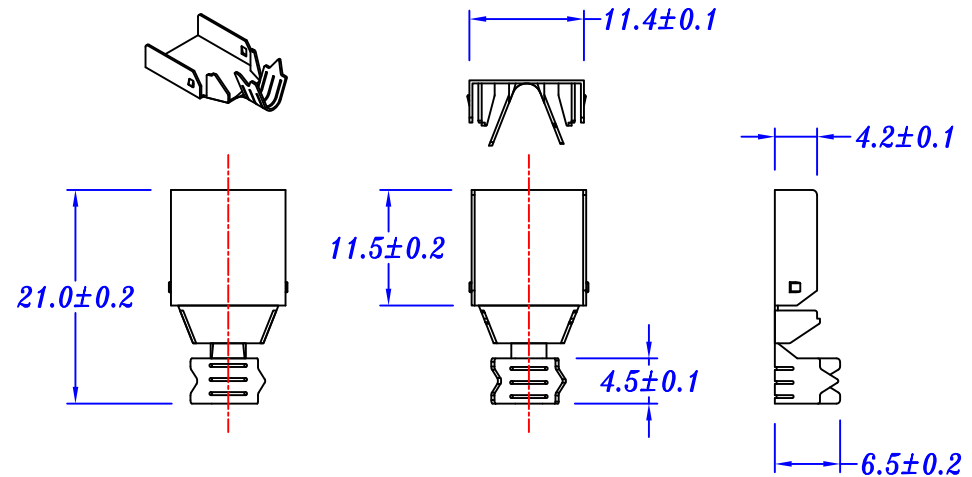
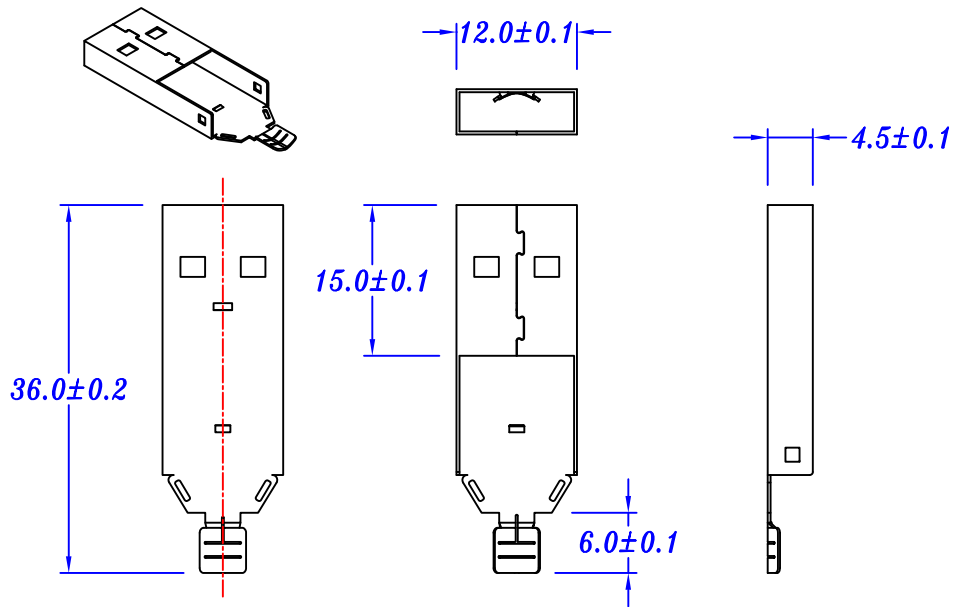
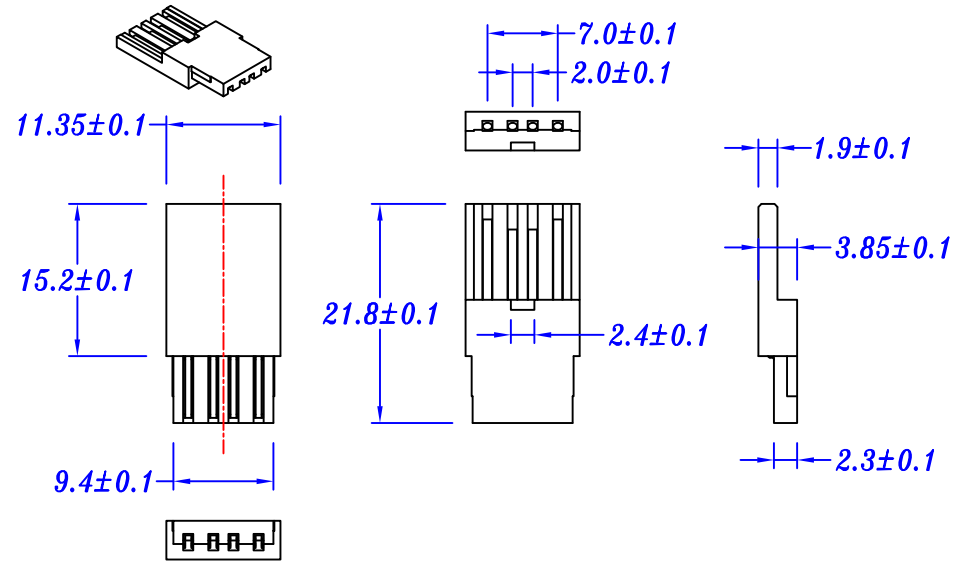

NO.410, FU-TEH 1ST ROAD,
SHIJR, TAIPEI COUNTY
221, TAIWAN, R.O.C.

TEL: 886-2-26945824

FAX: 886-2-26946971

TITLE

USB 2.0-A TYPE
Sloder (Male) 三件式

PARTS NO.

PND15-SAP

DWG, NO.

GENERAL TOLERANCE

DIM:
X. ±0.30
X.X ±0.20
X.XX ±0.10

DRAWN

CHECK

APPROVE

SCALE

DATE 103/10/30

DATE 103/12/14

DATE

UNIT MM **REV.** B